

# WB Series

*"The new generation of Milk Meters  
from Tru-Test"*

**TRU-TEST®**

## **Milk Meters**

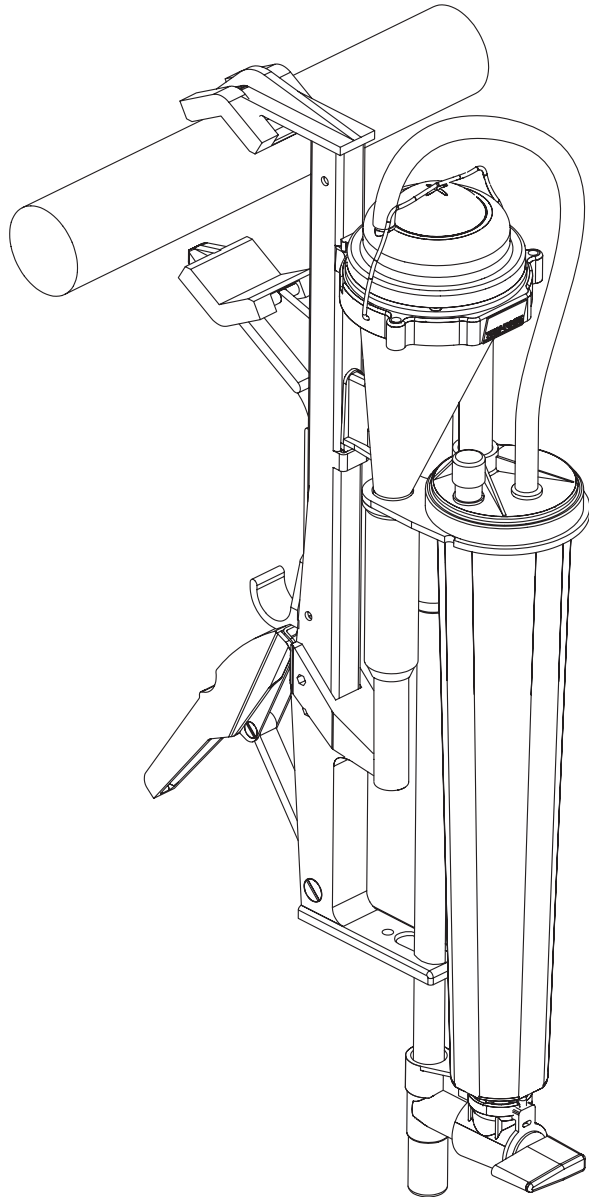

## W B A U T O S A M P L E R O P E R A T I N G I N S T R U C T I O N S

These instructions have been written to assist you with the installation and operation of your Tru-Test Milk Meter.

Please keep for your future reference.

For further assistance, your local Tru-Test distributor is trained and willing to help.

**D I S T R I B U T O R**

--

# Installation and Brackets

In all cases the Milk Meter should be mounted in a vertical position.

The Milk Meter should be located as close as possible to the milk line.

All milk hoses from the claw to the Milk Meter, and from the Milk Meter to the milk line, should be kept to a minimum to avoid excessive vacuum drop, slower milking and possible milk yield errors.

Your Milk Meter is equipped with one of the mounting brackets (or similar) shown below.

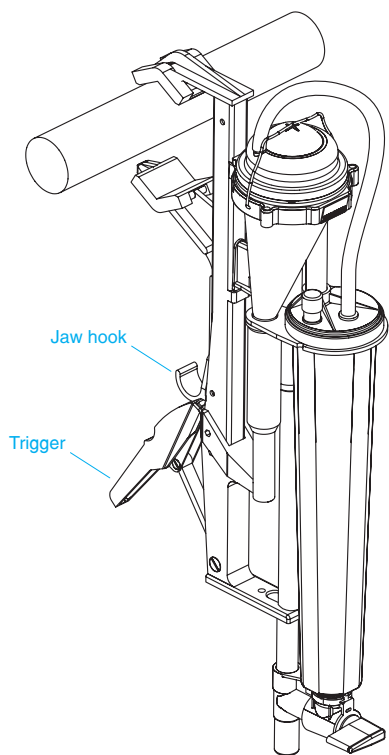

## Super-Clamp Bracket

To install, extend the jaws to the open position by pulling down on the jaw hook, place jaws over the pipe and hold bracket down whilst closing trigger to clamp firmly onto pipe. To remove, release trigger and push Meter up.

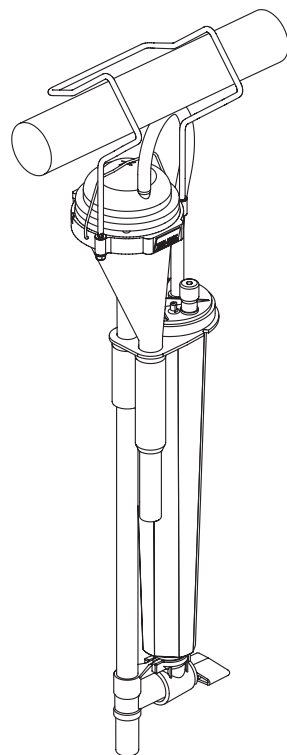

## Hanger Hook

Two sizes of Hanger Hooks are available; these being 90mm and 60mm. Simply hang Meter over pipework taking into account the above installation guide lines.

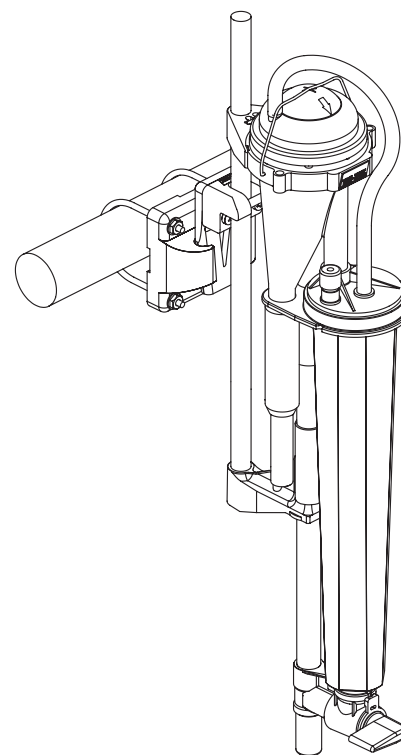

## Multi-Grip Bracket

To install, firmly attach dovetail flange to fascia board, steel member or pipe, with the slotted section in the vertical plane. Adjust the multi-grip dovetail to the height required on the tube bracket, then slide into dovetail flange.

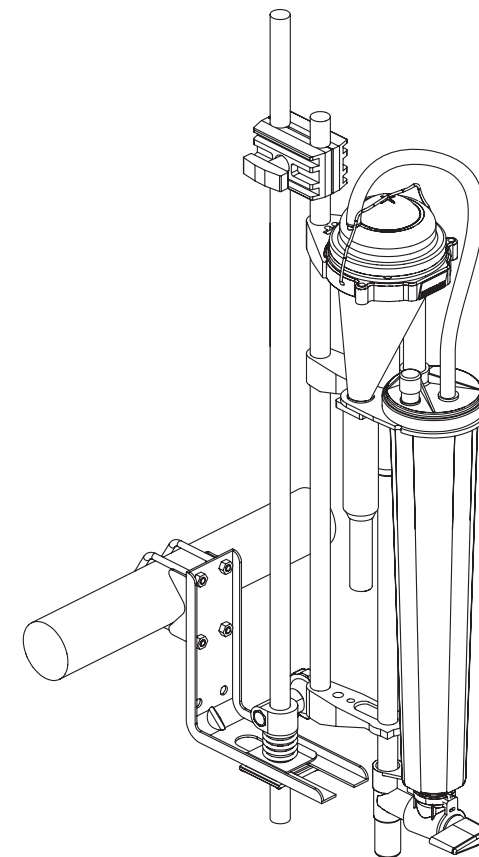

## Tube bracket

To install, firmly attach right angle flange to fascia board, steel member or pipe, with the slotted section in the horizontal plane. Slide the extendable tube through the clamp unit to adjust the height of the Meter.

# Connection of Hoses

Attach the milk hoses from the milking claw to the Milk Meter inlet tube, and from the Milk Meter outlet to the milk line. Ensure that hose lengths are kept to a minimum to avoid sagging and therefore possible errors in milk yield reading. If a take-off unit is used, connect your Milk Meter between the take-off and the milk line.

# Operating Your Meter Without the Sampler

Your Tru-Test Milk Meter can be used with or without the Sampler attached. For everyday use, where only the milk yield reading is required, connect the transfer tube directly from the meter cover to the flask top. Ensure valve is in the **Milk** position.

## At the end of milking

- Shut off the claw vacuum and remove the milking claw.
- Record the milk yield by reading from the bottom of the meniscus (i.e. do not include the froth at the top of the sample in the reading).
- To empty the flask, open the air admission valve by depressing the button for a minimum of 1 second. Your meter is now ready for the next cow. (The air admission valve will reset once the flask is empty.)
- The valve must be left in the milk position when not in use.

# Installing the Sampler

- Assemble the clamp unit as shown. Fit the stay provided.
- Slide the Sampler mounting bracket under the clamp then tighten the thumb screw.
- Remove the existing milk transfer tube.
- Attach the inlet tube to the flask top.
- Attach the exit tube to the meter cover.  
**Note:** Ensure that the small internal tube is not caught between the outer tube and nipple.
- Fit the vial to the Sampler.  
**Important:** Ensure entry and exit tubes are not restricted in any way. Restriction will cause inaccuracy.

## Milking Hook-Up

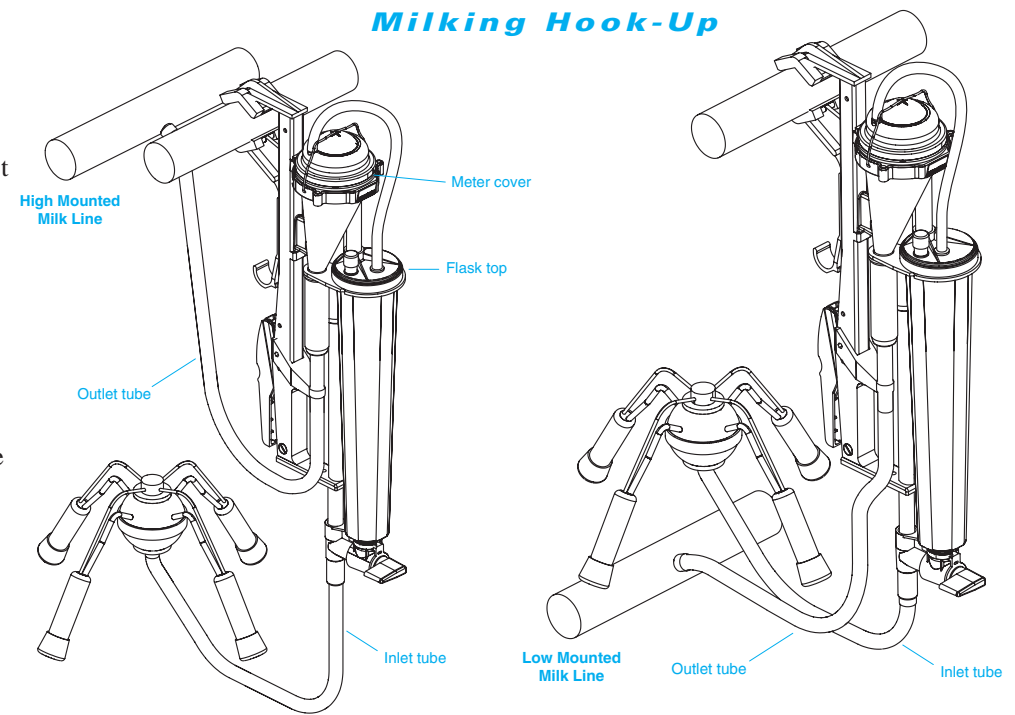

Push Down to Empty min. 1 second

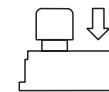

Milk



Wash



## Valve Positions

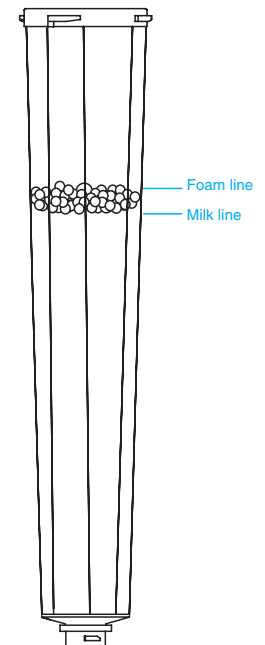

# Operating Your Meter with the Sampler

**Note:** The Sampler is delivered with the dial fully unwound (valve open). Turn the dial fully clockwise (valve closed) before milking.

## At the end of milking

- Shut off the claw vacuum and remove the milking claw.
- Record the milk yield by reading from the bottom of the meniscus (i.e. do not include the froth at the top of the sample in the reading).
- Turn the dial anti-clockwise (valve open) to the same reading as shown on the flask.  
**Important:** If you turn the dial too far, fully rewind it to zero, pause, then start again.
- To empty the flask, open the air admission valve by depressing the button for a minimum of 1 second. (The air admission valve will reset once the flask is empty.)  
**Note:** If the flask volume alters while setting the dial, reset by fully rewinding to zero, pause, then start again.
- Fully wind the dial out to maximum then rewind it back to zero and replace the vial with a new one. Your meter is now ready for the next cow.

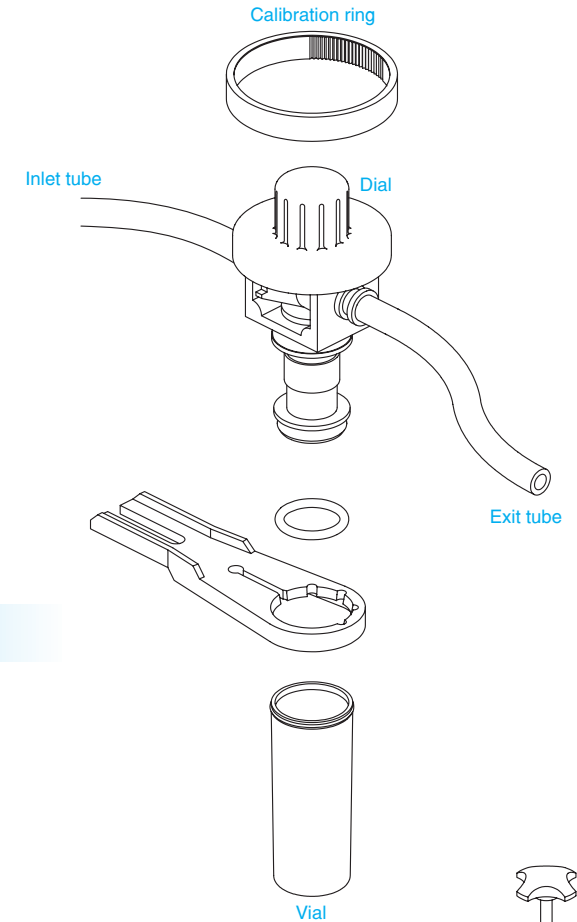

# Washing Your Meter and Sampler

## Manual Cleaning

Wipe exterior surfaces with a clean damp cloth to remove dirt.  
Wash the Milk Meter in a hot detergent solution and rinse thoroughly with clean warm water.

## Cleaning in Place

For your convenience, the Auto Sampler Milk Meter is designed for in-line washing.

- Connect hoses as shown below, and turn the valve to the **Wash** position.
- If a Sampler is fitted, set the dial to the middle position and leave in-line to wash with the meter. Ensure a vial is fitted for washing.
- Once a week, brush lightly around and inside the Sampler base and sealing ring groove.
- We recommend that abrasive detergents are not used, and that detergents are used at strengths recommended by the manufacturer.
- **The valve must be left in the milk position when not in use.**
- **The sampler should be left in the unwound (up position) when not in use.**

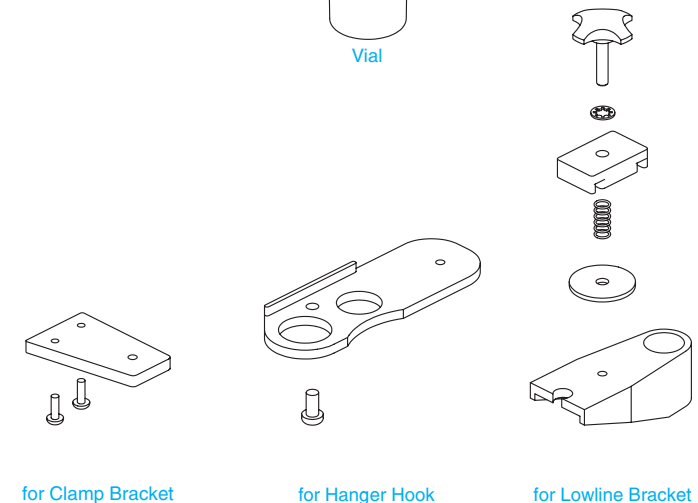

for Clamp Bracket

for Hanger Hook

for Lowline Bracket

**Washing Hook-up (if washed in place)**

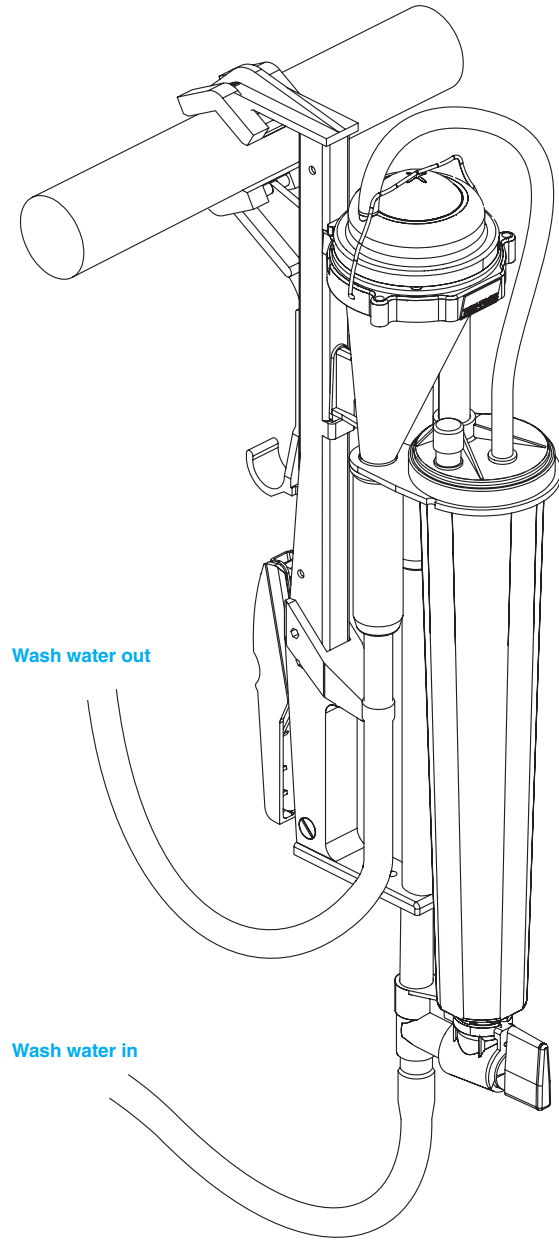

**Washing Hook-up  
(if washed in utensil room)**

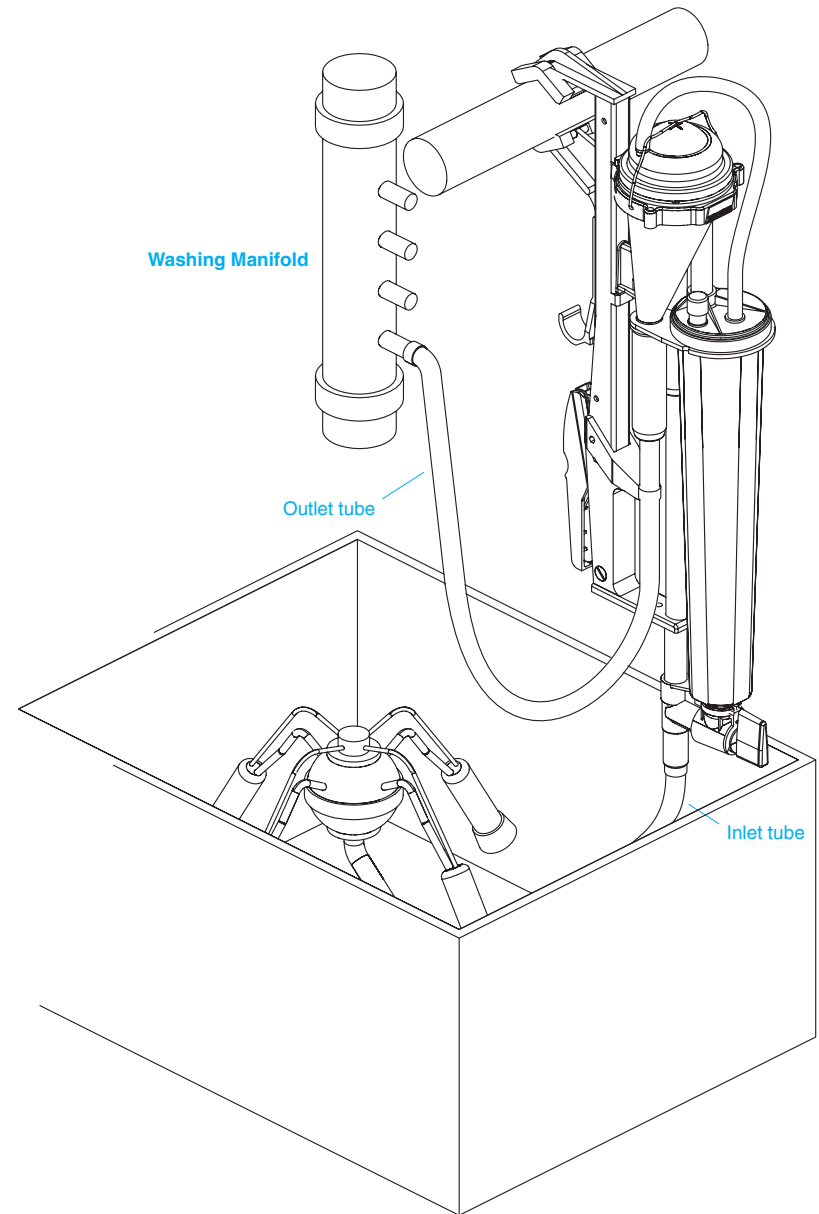

# Maintenance

Periodically disassemble the wash valve and smear valve inner and o-rings with a silicone base food grade lubricant. We recommend Dow Corning No.7 Release Compound (supplied in the Tru-Test Service Kit). Do not use Hydro-carbon (petroleum) based lubricants as damage to the valve, o-rings or grommet may occur, resulting in valve failure.

**When not in use, the wash valve must be left in the Milk position.**

When the Sampler is not in use, store out of direct sun light and fully unwind the dial.

The Sampler calibration ring should not be removed. If the Sampler requires calibration it should be sent to a service centre.

# Service Kit

To assist in maintaining your Milk Meter equipment, Tru-Test offers a service kit complete with all rubber components and easy to follow instructions. We recommend you service your WB Auto Sampler Milk Meter with the following parts provided in the Tru-Test service kit (part number MSK21000).

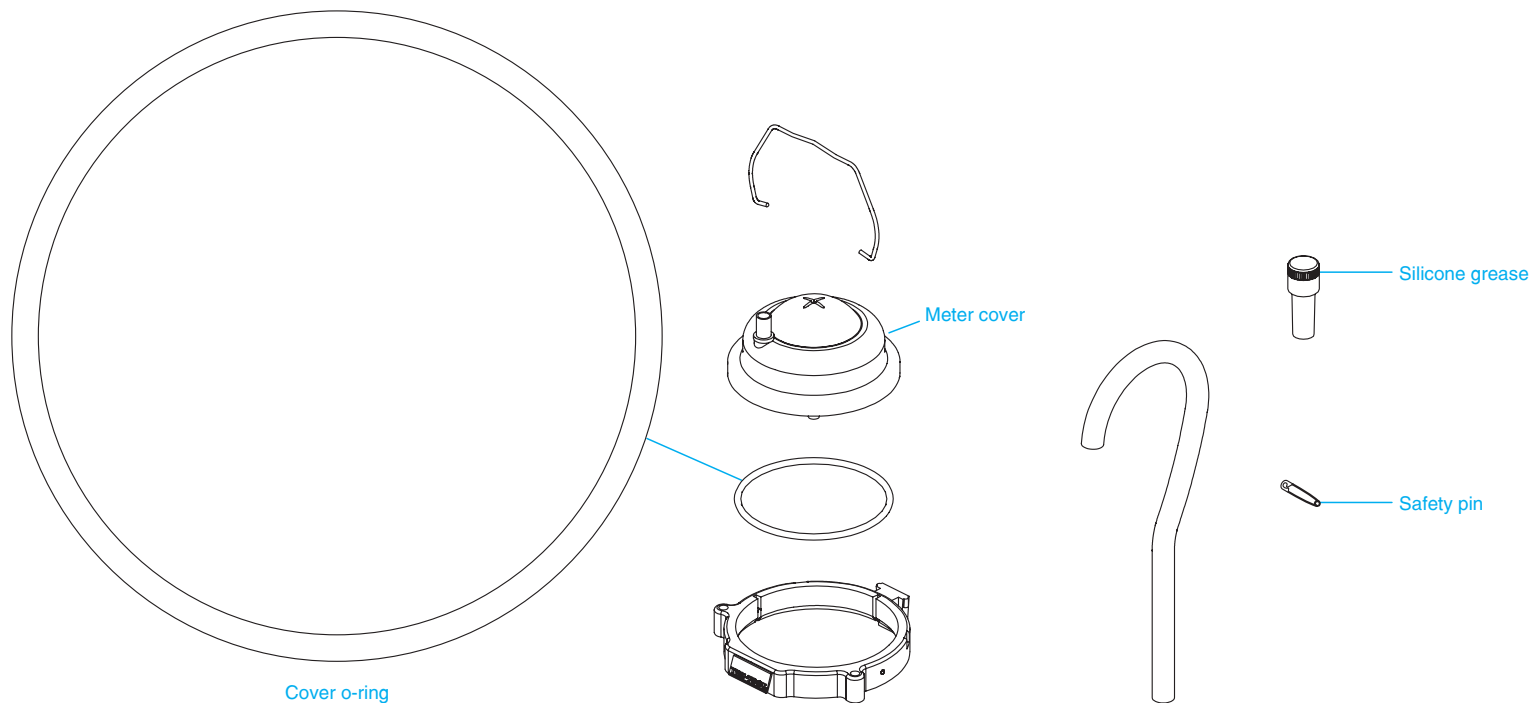

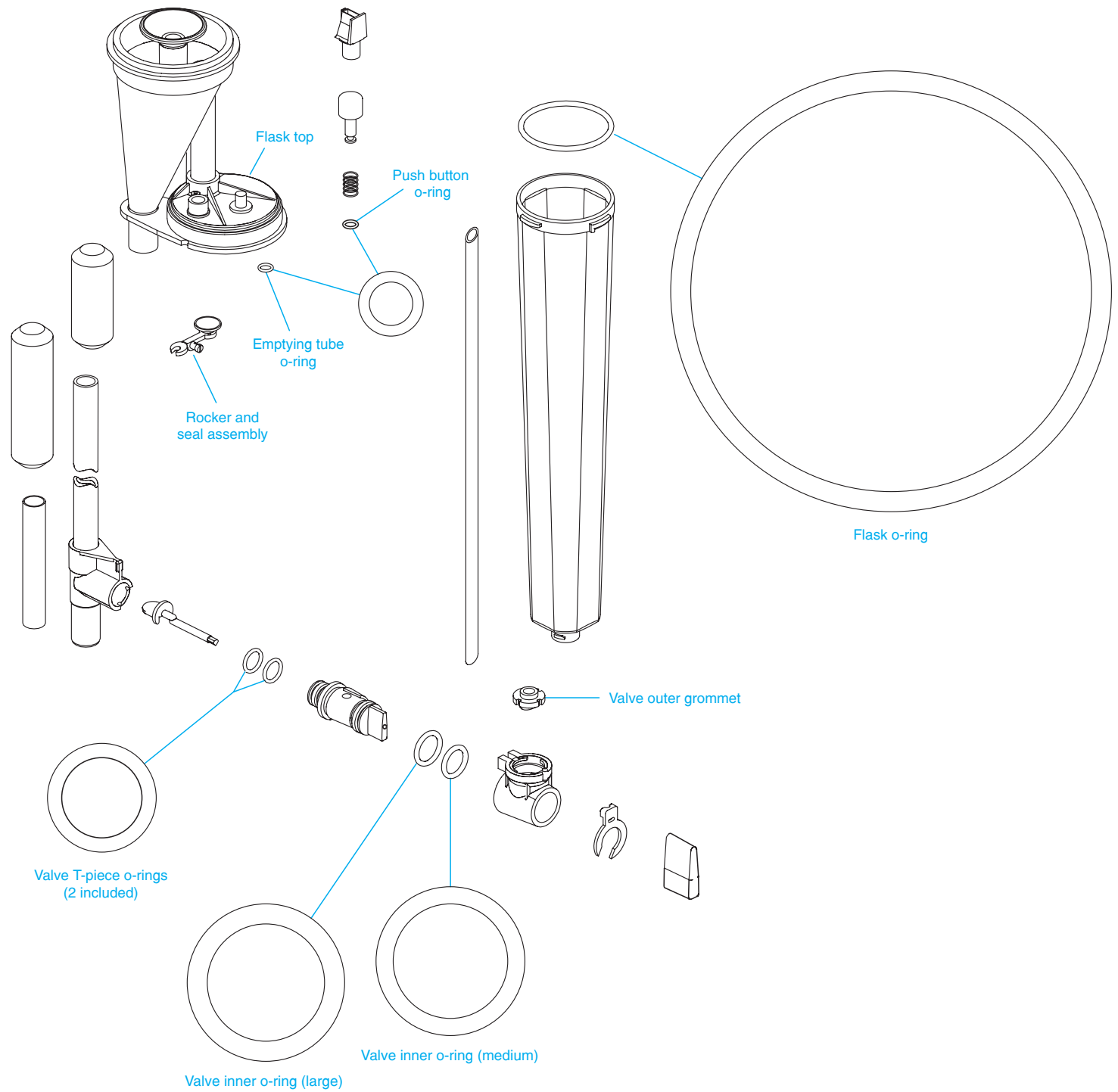

# TroubleShooting

## Symptom

## Solution

### Abnormal Reading

Milk Meter more than 5° from vertical	Reposition to vertical
Flask sealing ring leaking air	Replace flask sealing ring
Defective valve	Replace sealing rings or send Milk Meter to service centre
Insufficient vacuum	Have milking plant checked
Dirty Milk Meter	Remove from operation and clean
Air hole in cluster cap plugged	Clean air hole
Cracked cover or body	Replace cover or body
Cover deflector point damaged or blunt	Replace cover
Cracked flask	Replace flask
Partially plugged / obstructed nozzle	Carefully clean obstruction or nozzle
Damaged nozzle	Replace nozzle and recalibrate

### Flask Filling Too Fast

Hoses reversed	Install hoses correctly, milk cluster to Milk Meter inlet tube
Wrong nozzle used	Use proper nozzle size
Damaged cover or metering nozzle	Replace part or send Milk Meter to service centre
Valve in wrong position	Place valve in <b>Milk</b> position
Damaged or worn valve outer grommet	Replace grommet

### No Sample in Flask

Hoses not connected	Connect tightly
Flask seal in Milk Meter body pinched or missing	Replace flask seal and reseal properly
Damaged flask	Check sealing edge / replace or send to service centre
Rocker valve stuck	Free or replace rocker valve
Cracked cover or body	Replace cover or body
Partially plugged / obstructed nozzle	Carefully clean obstruction or nozzle
Damaged valve leaking air	Try another valve / if persists send to service centre
Valve not in <b>Milk</b> position	Turn to <b>Milk</b> position
Air admission valve open	Repair or replace air admission valve

# Product Guarantee

THIS PRODUCT IS GUARANTEED AGAINST FAILURE OR BREAKDOWN DURING NORMAL OR RECOMMENDED USE FOR ONE YEAR FROM THE DATE OF PURCHASE.

## Conditions of Guarantee

- The unit must have been used in accordance with the manufacturer's instructions supplied with each unit.
- The faulty unit must be returned to a service agent accredited by the distributor.
- This guarantee relates only to the standard of manufacture and the manufacturer will not be liable for any injury or damage sustained in the use of the product.
- This guarantee covers defective parts and faulty workmanship; it does not extend to wear and tear and defects resulting from other factors. It shall not apply when the unit has not been continuously in the possession of the purchaser.
- All claims under the guarantee must be made through the outlet from whom the unit was purchased and they will refer the claim to the distributor.

**TRU-TEST®**

Tru-Test Limited, Auckland, New Zealand, [www.tru-test.com](http://www.tru-test.com)